

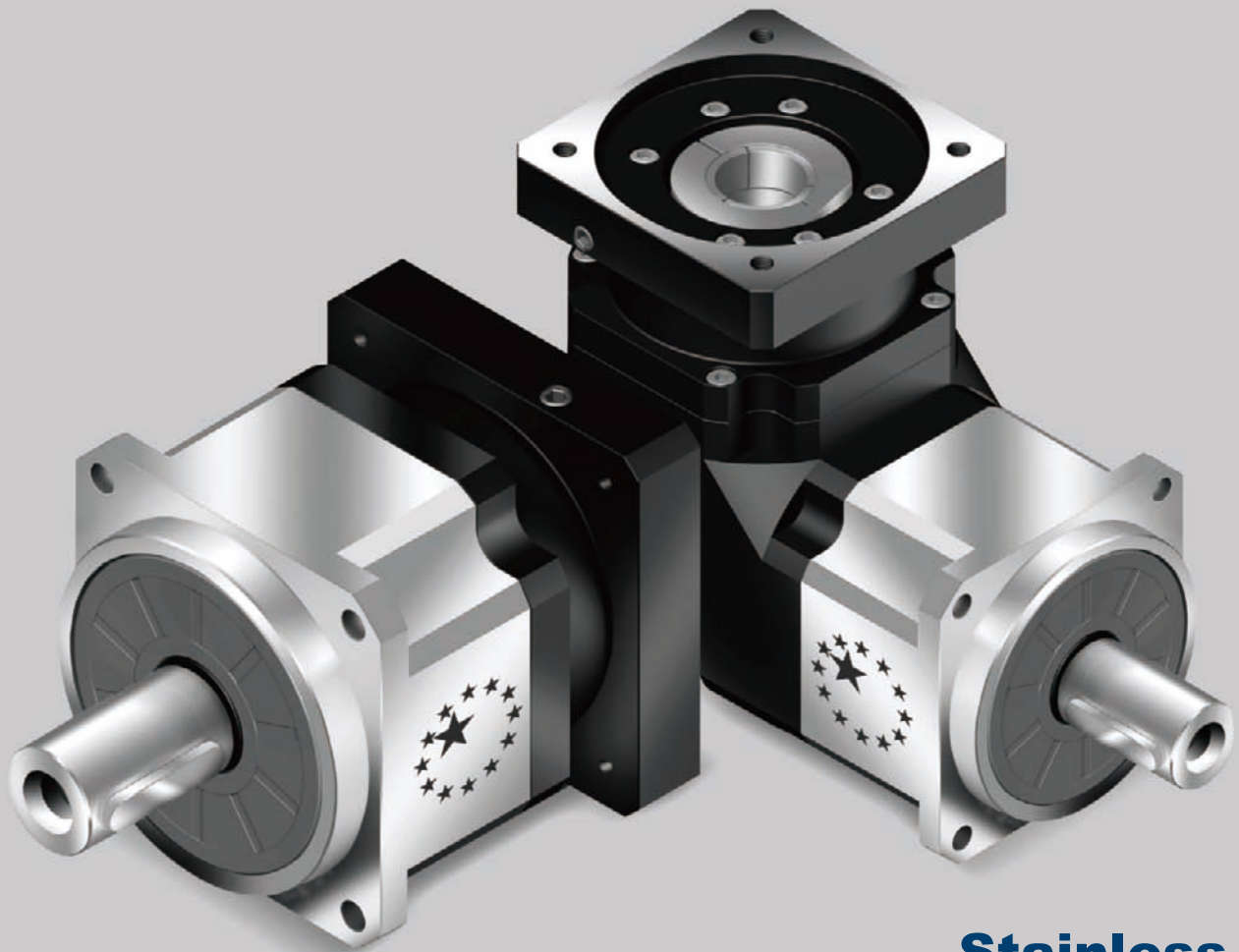

APEX DYNAMICS, INC.

**高精度
行星式减速机
AB / ABR 系列**



Stainless

AB 系列

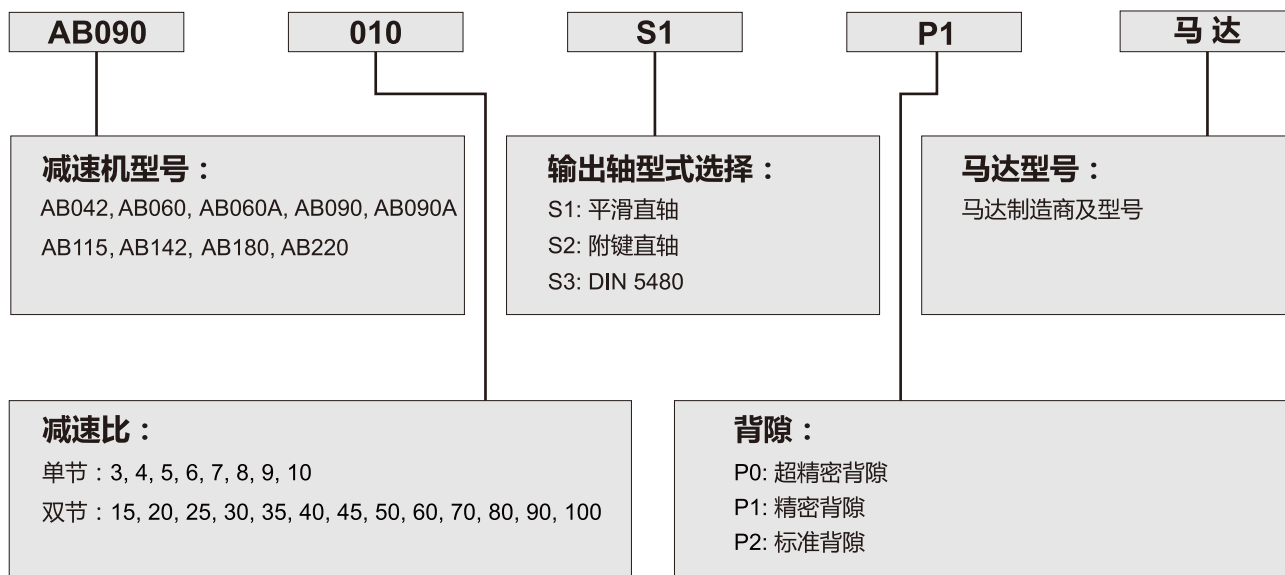

选用范例 : AB090- 010- S1- P1 / SIEMENS 1FT6 041- 4AF71

ABR 系列

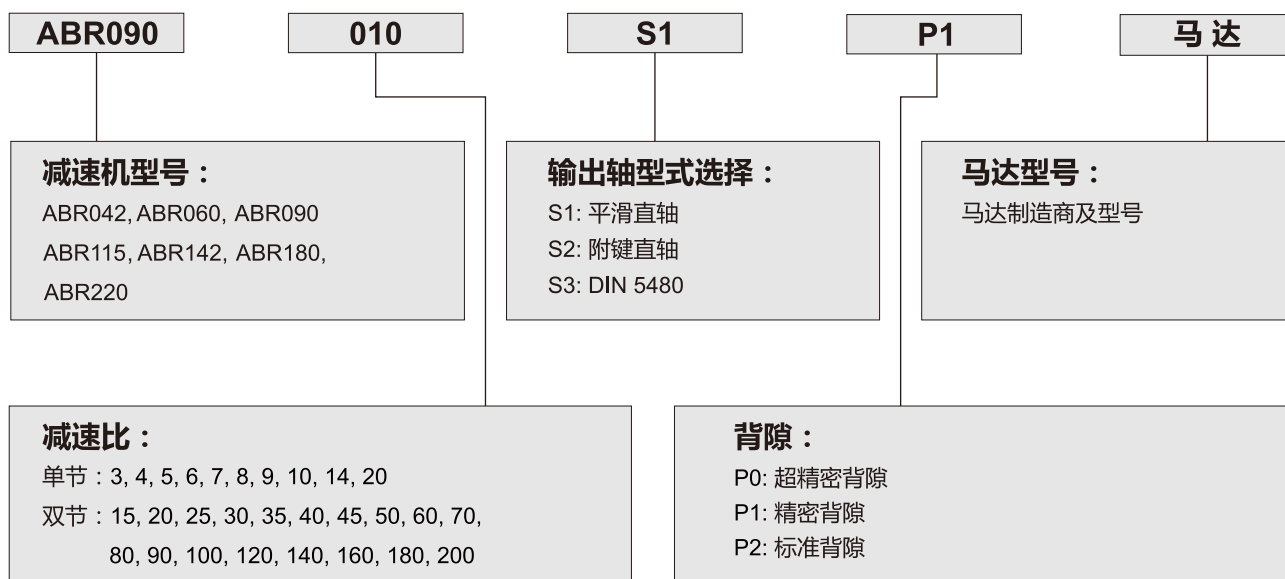

选用范例 : ABR090- 010- S1- P1 / SIEMENS 1FT6 041- 4AF71

©2017台湾精锐科技股份有限公司

台湾精锐科技股份有限公司保留所有技术细节、插图以及工程图面的修改权利，本型录之产品细节将随未来发展及必要设定进行调整。最新产品资讯及变动，请洽询网站<http://www.apexdyna.com/>。

AB系列产品规格

杭州摩森机电科技有限公司
http://www.hzmosen.com

咨询热线 0571-86622450

减速机性能资料

规格	节数	减速比 ^A	AB042	AB060	AB060A	AB090	AB090A	AB115	AB142	AB180	AB220	
额定输出力矩 T _{2N}	1	3	20	55	-	130	-	208	342	588	1,140	
		4	19	50	-	140	-	290	542	1,050	1,700	
		5	22	60	-	160	-	330	650	1,200	2,000	
		6	20	55	-	150	-	310	600	1,100	1,900	
		7	19	50	-	140	-	300	550	1,100	1,800	
		8	17	45	-	120	-	260	500	1,000	1,600	
		9	14	40	-	100	-	230	450	900	1,500	
		10	14	40	-	100	-	230	450	900	1,500	
		2	15	20	55	55	130	130	208	342	588	1,140
			20	19	50	50	140	140	290	542	1,050	1,700
	25		22	60	60	160	160	330	650	1,200	2,000	
	30		20	55	55	150	150	310	600	1,100	1,900	
	35		19	50	50	140	140	300	550	1,100	1,800	
	40		17	45	45	120	120	260	500	1,000	1,600	
	45		14	40	40	100	100	230	450	900	1,500	
	50		22	60	60	160	160	330	650	1,200	2,000	
	60		20	55	55	150	150	310	600	1,100	1,900	
	70		19	50	50	140	140	300	550	1,100	1,800	
80	17	45	45	120	120	260	500	1,000	1,600			
90	14	40	40	100	100	230	450	900	1,500			
100	14	40	40	100	100	230	450	900	1,500			
急停力矩 T _{2NOT} ^B	Nm	1,2	3倍额定输出力矩									
额定输入转速 n _{1N}	rpm	1,2	3~100	5,000	5,000	5,000	4,000	4,000	4,000	3,000	3,000	2,000
最大输入转速 n _{1B}	rpm	1,2	3~100	10,000	10,000	10,000	8,000	8,000	8,000	6,000	6,000	4,000
超精密背隙 P0	arcmin	1	3~10	-	-	-	≤1	-	≤1	≤1	≤1	≤1
		2	15~100	-	-	-	-	-	≤3	≤3	≤3	≤3
精密背隙 P1	arcmin	1	3~10	≤3	≤3	-	≤3	-	≤3	≤3	≤3	≤3
		2	15~100	≤5	≤5	≤5	≤5	≤5	≤5	≤5	≤5	≤5
标准背隙 P2	arcmin	1	3~10	≤5	≤5	-	≤5	-	≤5	≤5	≤5	≤5
		2	15~100	≤7	≤7	≤7	≤7	≤7	≤7	≤7	≤7	≤7
扭转刚性	Nm/arcmin	1,2	3~100	3	7	7	14	14	25	50	145	225
容许径向力 F _{2B} ^C	N	1,2	3~100	780	1,530	1,530	3,250	3,250	6,700	9,400	14,500	50,000
容许轴向力 F _{2aB} ^C	N	1,2	3~100	390	765	765	1,625	1,625	3,350	4,700	7,250	25,000
使用寿命 ^D	hr	1,2	3~100									
效率 η	%	1	3~10									
		2	15~100									
重量	kg	1	3~10	0.6	1.3	-	3.7	-	7.8	14.5	29	48
		2	15~100	0.8	1.5	1.9	4.1	5.3	9	17.5	33	60
使用温度	°C	1,2	3~100									
润滑			-10°C~90°C									
防护等级			合成润滑油脂									
安装方向			IP65									
噪音值(n ₁ =3000rpm,i=10,无负载) ^E	dB(A)	1,2	3~100	≤56	≤58	≤60	≤60	≤63	≤63	≤65	≤67	≤70

减速机转动惯量

规格	节数	减速比 ^A	AB042	AB060	AB060A	AB090	AB090A	AB115	AB142	AB180	AB220	
转动惯量 J ₁	1	3	0.03	0.16	-	0.61	-	3.25	9.21	28.98	69.61	
		4	0.03	0.14	-	0.48	-	2.74	7.54	23.67	54.37	
		5	0.03	0.13	-	0.47	-	2.71	7.42	23.29	53.27	
		6	0.03	0.13	-	0.45	-	2.65	7.25	22.75	51.72	
		7	0.03	0.13	-	0.45	-	2.62	7.14	22.48	50.97	
		8	0.03	0.13	-	0.44	-	2.58	7.07	22.59	50.84	
		9	0.03	0.13	-	0.44	-	2.57	7.04	22.53	50.63	
		10	0.03	0.13	-	0.44	-	2.57	7.03	22.51	50.56	
		2	15	0.03	0.03	0.13	0.13	0.47	0.47	2.71	7.42	23.29
			20	0.03	0.03	0.13	0.13	0.47	0.47	2.71	7.42	23.29
	25		0.03	0.03	0.13	0.13	0.47	0.47	2.71	7.42	23.29	
	30		0.03	0.03	0.13	0.13	0.47	0.47	2.71	7.42	23.29	
	35		0.03	0.03	0.13	0.13	0.47	0.47	2.71	7.42	23.29	
	40		0.03	0.03	0.13	0.13	0.47	0.47	2.71	7.42	23.29	
	45		0.03	0.03	0.13	0.13	0.47	0.47	2.71	7.42	23.29	
	50		0.03	0.03	0.13	0.13	0.44	0.44	2.57	7.03	22.51	
	60		0.03	0.03	0.13	0.13	0.44	0.44	2.57	7.03	22.51	
	70		0.03	0.03	0.13	0.13	0.44	0.44	2.57	7.03	22.51	
80	0.03	0.03	0.13	0.13	0.44	0.44	2.57	7.03	22.51			
90	0.03	0.03	0.13	0.13	0.44	0.44	2.57	7.03	22.51			
100	0.03	0.03	0.13	0.13	0.44	0.44	2.57	7.03	22.51			

A. 减速比 (i=N_{in}/N_{out})

B. 最大输出力矩 T_{2B} = 60% of T_{2NOT}

C. 输出转速100RPM时候, 并作用于输出轴中心位置

D. 连续运转使用寿命低于10000小时

E. 以减速机减速比10(单节)与减速比100(双节)转速为3000rpm且无负载状态下测得数据

AB系列尺寸 (单节, 减速比 $i=3\sim 10$)

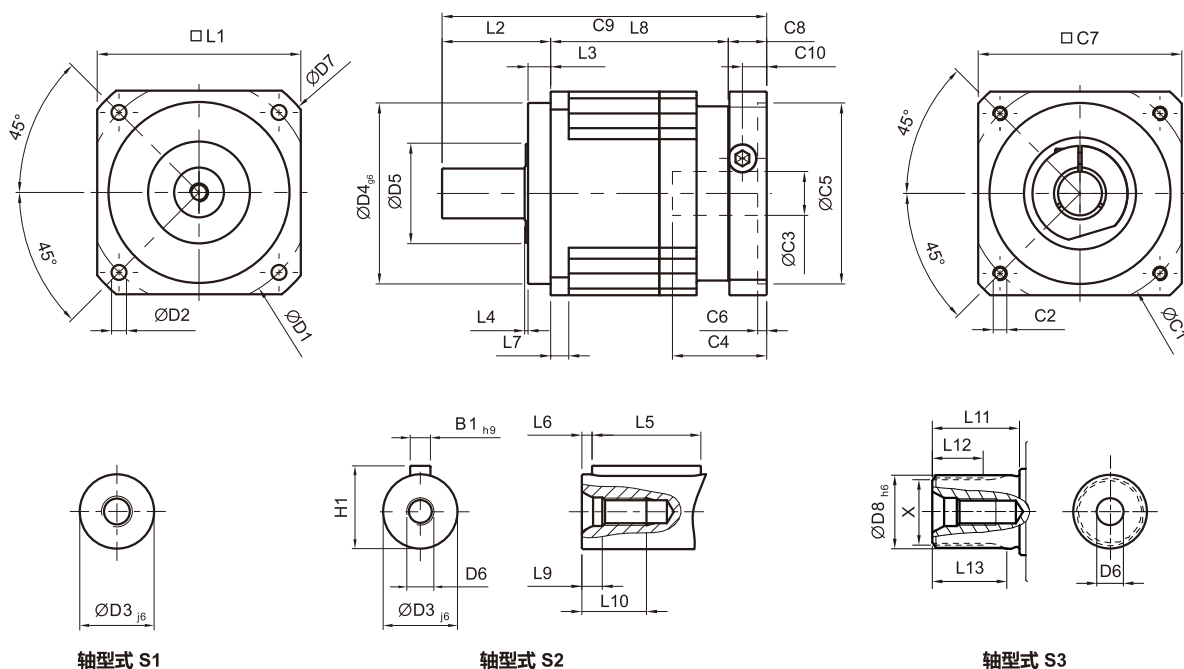

轴型式 S1

轴型式 S2

轴型式 S3

[unit: mm]

尺寸	AB042	AB060	AB090	AB115	AB142	AB180	AB220
D1	50	70	100	130	165	215	250
D2	3.4	5.5	6.6	9	11	13	17
D3 _{j6}	13	16	22	32	40	55	75
D4 _{g6}	35	50	80	110	130	160	180
D5	22	45	65	95	75	95	115
D6	M4 x 0.7P	M5 x 0.8P	M8 x 1.25P	M12 x 1.75P	M16 x 2P	M20 x 2.5P	M20 x 2.5P
D7	56	80	116	152	185	240	292
D8 _{h6}	-	16	22	32	40	55	75
L1	42	60	90	115	142	180	220
L2	26	37	48	65	97	105	138
L3	5.5	7	10	12	15	20	30
L4	1	1.5	1.5	2	3	3	3
L5	16	25	32	40	63	70	90
L6	2	2	3	5	5	6	7
L7	4	6	8	10	12	15	20
L8	31	61	78.5	102	119.5	154	163.5
L9	4.5	4.8	7.2	10	12	15	15
L10	10	12.5	19	28	36	42	42
L11	-	26	26	26	40	41.5	52
L12	-	15	15	15	20	21.5	28
L13	-	21	22.5	23	33.5	33.5	45
C1 ¹	46	70	100	130	165	215	235
C2 ¹	M4 x 0.7P	M5 x 0.8P	M6 x 1P	M8 x 1.25P	M10 x 1.5P	M12 x 1.75P	M12 x 1.75P
C3 ¹	≤11 / ≤12 ²	≤14 / ≤16 ²	≤19 / ≤24	≤32	≤38	≤48	≤55
C4 ¹	25	34	40	50	60	85	116
C5 ¹	30	50	80	110	130	180	200
C6 ¹	3.5	8	4	5	6	6	6
C7 ¹	42	60	90	115	142	190	220
C8 ¹	29.5	19	17	19.5	22.5	29	63
C9 ¹	86.5	117	143.5	186.5	239	288	364.5
C10 ¹	8.75	13.5	10.75	13	15	20.75	53
B1 _{h9}	5	5	6	10	12	16	20
H1	15	18	24.5	35	43	59	79.5
X DIN5480	-	W16x0.8x 30x18x6m	W22x1.25x 30x16x6m	W32x1.25x 30x24x6m	W40x2x 30x18x6m	W55x2x 30x26x6m	W70x2x 30x34x6m

1. C1~C10是公制标准马达连接板之尺寸, 请上网点选“减速机选用”找出正确之尺寸。

2. AB042 5,10减速比提供C3≤12可选; AB060 5,10减速比提供C3≤16可选;

AB系列尺寸 (双节, 减速比 i=15~100)

杭州摩森机电科技有限公司
http://www.hzmosen.com

咨询热线 0571-86622450

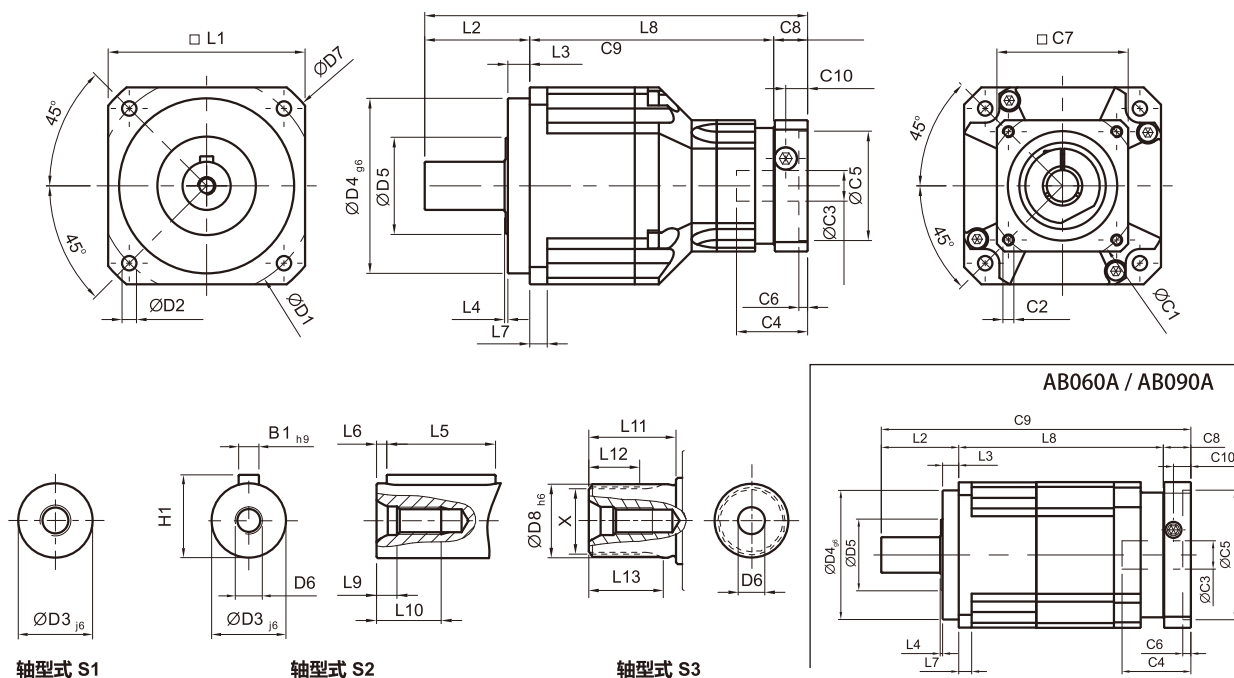

[unit: mm]

尺寸	AB042	AB060	AB060A	AB090	AB090A	AB115	AB142	AB180	AB220
D1	50	70		100		130	165	215	250
D2	3.4	5.5		6.6		9	11	13	17
D3 _{j6}	13	16		22		32	40	55	75
D4 _{g6}	35	50		80		110	130	160	180
D5	22	45		65		95	75	95	115
D6	M4 x 0.7P	M5 x 0.8P		M8 x 1.25P		M12 x 1.75P	M16 x 2P	M20 x 2.5P	M20 x 2.5P
D7	56	80		116		152	185	240	292
D8 _{h6}	-	16		22		32	40	55	75
L1	42	60		90		115	142	180	220
L2	26	37		48		65	97	105	138
L3	5.5	7		10		12	15	20	30
L4	1	1.5		1.5		2	3	3	3
L5	16	25		32		40	63	70	90
L6	2	2		3		5	5	6	7
L7	4	6		8		10	12	15	20
L8	58.5	72	98	111.5	126.5	143.5	176	209.5	248
L9	4.5	4.8		7.2		10	12	15	15
L10	10	12.5		19		28	36	42	42
L11	-	26		26		26	40	41.5	52
L12	-	15		15		15	20	21.5	28
L13	-	21		22.5		23	33.5	33.5	45
C1 ³	46	46	70	70	100	100	130	165	215
C2 ³	M4 x 0.7P	M4 x 0.7P	M5 x 0.8P	M5 x 0.8P	M6 x 1P	M6 x 1P	M8 x 1.25P	M10 x 1.5P	M12 x 1.75P
C3 ³	≤11/≤12	≤11/≤12	≤14/≤16	≤14/≤15,875/≤16	≤19/≤24	≤19/≤24	≤32	≤38	≤48
C4 ³	25	25	34	34	40	40	50	60	85
C5 ³	30	30	50	50	80	80	110	130	180
C6 ³	3.5	3.5	8	8	4	4	5	6	6
C7 ³	42	42	60	60	90	90	115	142	190
C8 ³	29.5	29.5	19	19	17	17	19.5	22.5	29
C9 ³	114	138.5	154	178.5	191.5	225.5	292.5	337	415
C10 ³	8.75	8.75	13.5	13.5	10.75	10.75	13	15	20.75
B1 _{h9}	5	5		6		10	12	16	20
H1	15	18		24.5		35	43	59	79.5
X DIN5480	-	W16x0.8x 30x18x6m		W22x1.25x 30x16x6m		W32x1.25x 30x24x6m	W40x2x 30x18x6m	W55x2x 30x26x6m	W70x2x 30x34x6m

3. C1~C10是公制标准马达连接板的尺寸, 请上网点选 减速机选用 找出正确之尺寸。

ABR系列规格

减速机性能资料

规格		节数	减速比 ^A	ABR042	ABR060	ABR090	ABR115	ABR142	ABR180	ABR220	
额定输出力矩 T_{2N}	Nm	1	3	9	36	90	195	342	588	1,140	
			4	12	48	120	260	520	1,040	1,680	
			5	15	60	150	325	650	1,200	2,000	
			6	18	55	150	310	600	1,100	1,900	
			7	19	50	140	300	550	1,100	1,800	
			8	17	45	120	260	500	1,000	1,600	
			9	14	40	100	230	450	900	1,500	
			10	14	60	150	325	650	1,200	2,000	
			14	-	42	140	300	550	1,100	1,800	
			20	-	40	100	230	450	900	1,500	
		2	15	14	-	-	-	-	-	-	-
			20	14	-	-	-	-	-	-	-
			25	15	60	150	325	650	1,200	2,000	
			30	20	55	150	310	600	1,100	1,900	
			35	19	50	140	300	550	1,100	1,800	
			40	17	45	120	260	500	1,000	1,600	
			45	14	40	100	230	450	900	1,500	
			50	14	60	100	230	650	1,200	2,000	
			60	20	55	150	310	600	1,100	1,900	
			70	19	50	140	300	550	1,100	1,800	
80	17	45	120	260	500	1,000	1,600				
90	14	40	100	230	450	900	1,500				
100	14	40	100	230	450	900	1,500				
120	-	-	150	310	600	1,100	1,900				
140	-	-	140	300	550	1,100	1,800				
160	-	-	120	260	550	1,000	1,600				
180	-	-	100	230	450	900	1,500				
200	-	-	100	230	450	900	1,500				
急停力矩 T_{2NOT}^B	Nm	1,2	3~200	3倍额定输出力矩							
额定输入转速 n_{1N}	rpm	1,2	3~200	5,000	5,000	4,000	4,000	3,000	3,000	2,000	
最大输入转速 n_{1B}	rpm	1,2	3~200	10,000	10,000	8,000	8,000	6,000	6,000	4,000	
超精密背隙 P0	arcmin	1	3~20	-	-	≤2	≤2	≤2	≤2	≤2	
		2	25~200	-	-	≤4	≤4	≤4	≤4	≤4	
精密背隙 P1	arcmin	1	3~20	≤4	≤4	≤4	≤4	≤4	≤4	≤4	
		2	25~200	≤7	≤7	≤7	≤7	≤7	≤7	≤7	
标准背隙 P2	arcmin	1	3~20	≤6	≤6	≤6	≤6	≤6	≤6	≤6	
		2	25~200	≤9	≤9	≤9	≤9	≤9	≤9	≤9	
扭转刚性	Nm/arcmin	1,2	3~200	3	7	14	25	50	145	225	
容许径向力 F_{2rB}^C	N	1,2	3~200	780	1,530	3,250	6,700	9,400	14,500	50,000	
容许轴向力 F_{2aB}^C	N	1,2	3~200	390	765	1,625	3,350	4,700	7,250	25,000	
使用寿命 ^D	hr	1,2	3~200	20,000							
效率 η	%	1	3~20	≥95%							
		2	25~200	≥92%							
重量	kg	1	3~20	0.9	2.1	6.4	13	24.5	51	83	
		2	25~200	1.2	1.5	7.8	14.2	27.5	54	95	
使用温度	°C	1,2	3~200	-10°C~+90°C							
润滑				合成润滑油脂							
防护等级		1,2	3~200	IP65							
安装方向		1,2	3~200	任意方向							
噪音值($n_r=3000\text{rpm}, i=10$, 无负载) ^E	dB(A)	1,2	3~200	≤61	≤63	≤65	≤68	≤70	≤72	≤74	

减速机转动惯量

规格		节数	减速比 ^A	ABR042	ABR060	ABR090	ABR115	ABR142	ABR180	ABR220
转动惯量 J_1	$\text{kg} \cdot \text{cm}^2$	1	3~10	0.09	0.35	2.25	6.84	23.4	68.9	135.4
			14	-	0.07	1.87	6.25	21.8	65.6	119.8
			20	-	0.07	1.87	6.25	21.8	65.6	119.8
		2	15	0.09	-	-	-	-	-	-
			20	0.09	-	-	-	-	-	-
			25~100	0.09	0.09	0.35	2.25	6.84	23.4	68.9
120~200	-	-	0.31	1.87	6.25	21.8	65.6			

A. 减速比 ($i=N_{in}/N_{out}$)

B. 最大输出力矩 $T_{2B}=60\%$ of T_{2NOT}

C. 输出转速100RPM时候, 并作用于输出轴中心位置

D. 连续运转使用寿命低于10000小时

E. 以减速机减速比10(单节)与减速比100(双节)转速为3000rpm且无负载状态下测得数据

ABR系列尺寸 (单节, 减速比 i=3~20)

杭州摩森机电科技有限公司
http://www.hzmosen.com

咨询热线 0571-86622450

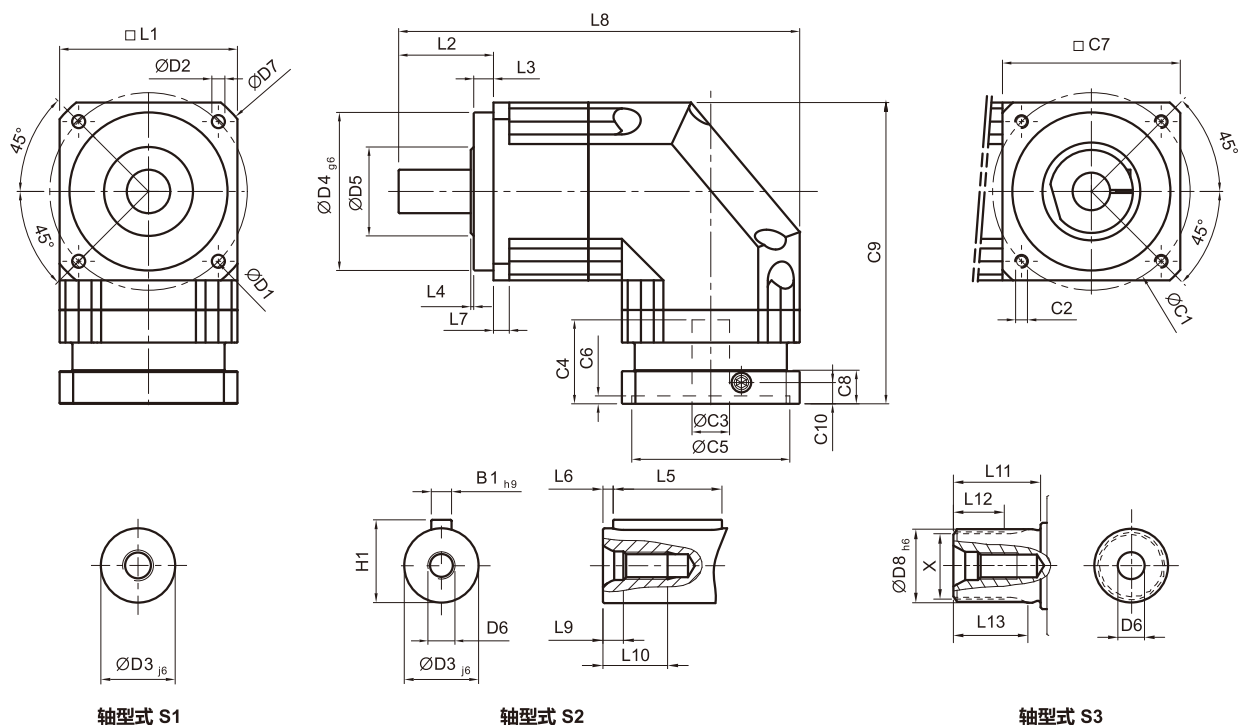

轴型式 S1

轴型式 S2

轴型式 S3

[unit: mm]

尺寸	ABR042	ABR060	ABR090	ABR115	ABR142	ABR180	ABR220
D1	50	70	100	130	165	215	250
D2	3.4	5.5	6.6	9	11	13	17
D3 _{j6}	13	16	22	32	40	55	75
D4 _{g6}	35	50	80	110	130	160	180
D5	22	45	65	95	75	95	115
D6	M4 x 0.7P	M5 x 0.8P	M8 x 1.25P	M12 x 1.75P	M16 x 2P	M20 x 2.5P	M20 x 2.5P
D7	56	80	116	152	185	240	292
D8 _{h6}	-	16	22	32	40	55	75
L1	42	60	90	115	142	180	220
L2	26	37	48	65	97	105	138
L3	5.5	7	10	12	15	20	30
L4	1	1.5	1.5	2	3	3	3
L5	16	25	32	40	63	70	90
L6	2	2	3	5	5	6	7
L7	4	6	8	10	12	15	20
L8	111.5	145	203	259	333	394	484
L9	4.5	4.8	7.2	10	12	15	15
L10	10	12.5	19	28	36	42	42
L11	-	26	26	26	40	41.5	52
L12	-	15	15	15	20	21.5	28
L13	-	21	22.5	23	33.5	33.5	45
C1 ¹	46	70	100	130	165	215	235
C2 ¹	M4 x 0.7P	M5 x 0.8P	M6 x 1P	M8 x 1.25P	M10 x 1.5P	M12 x 1.75P	M12 x 1.75P
C3 ¹	≤11 / ≤12	≤14 / ≤16	≤19 / ≤24	≤32	≤38	≤48	≤55
C4 ¹	25	34	40	50	60	85	116
C5 ¹	30	50	80	110	130	180	200
C6 ¹	3.5	8	4	5	6	6	6
C7 ¹	42	60	90	115	142	190	220
C8 ¹	29.5	19	17	19.5	22.5	29	63
C9 ¹	90.5	111.5	152.5	191.5	235.5	303.5	378.5
C10 ¹	8.75	13.5	10.75	13	15	20.75	53
B1 _{h9}	5	5	6	10	12	16	20
H1	15	18	24.5	35	43	59	79.5
X DIN5480	-	W16x0.8x 30x18x6m	W22x1.25x 30x16x6m	W32x1.25x 30x24x6m	W40x2x 30x18x6m	W55x2x 30x26x6m	W70x2x 30x34x6m

1. C1 C10是公制标准马达连接板的尺寸, 请上网点选 减速机选用 找出正确之尺寸。

ABR系列尺寸 (双节, 减速比 $i=15\sim 200$)

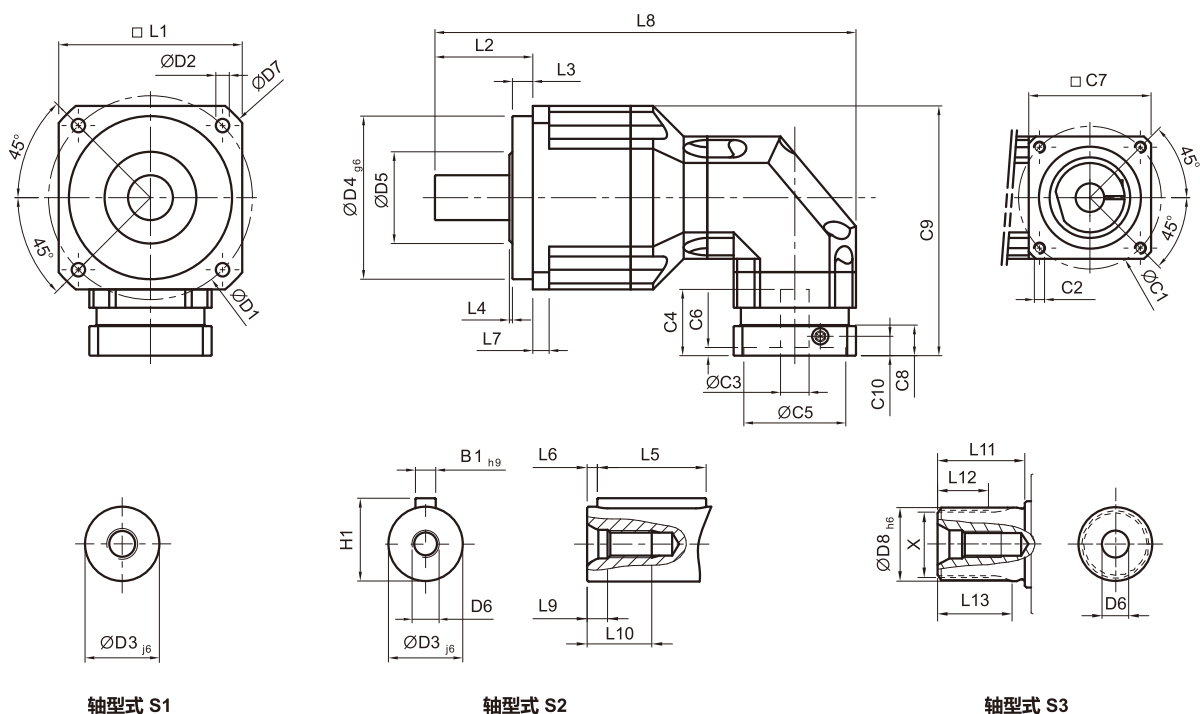

轴型式 S1

轴型式 S2

轴型式 S3

[unit: mm]

尺寸	ABR042	ABR060	ABR090	ABR115	ABR142	ABR180	ABR220
D1	50	70	100	130	165	215	250
D2	3.4	5.5	6.6	9	11	13	17
D3 _{j6}	13	16	22	32	40	55	75
D4 _{g6}	35	50	80	110	130	160	180
D5	22	45	65	95	75	95	115
D6	M4 x 0.7P	M5 x 0.8P	M8 x 1.25P	M12 x 1.75P	M16 x 2P	M20 x 2.5P	M20 x 2.5P
D7	56	80	116	152	185	240	292
D8 _{h6}	-	16	22	32	40	55	75
L1	42	60	90	115	142	180	220
L2	26	37	48	65	97	105	138
L3	5.5	7	10	12	15	20	30
L4	1	1.5	1.5	2	3	3	3
L5	16	25	32	40	63	70	90
L6	2	2	3	5	5	6	7
L7	4	6	8	10	12	15	20
L8	139	163.5	206.5	285	365	431	521
L9	4.5	4.8	7.2	10	12	15	15
L10	10	12.5	19	28	36	42	42
L11	-	26	26	26	40	41.5	52
L12	-	15	15	15	20	21.5	28
L13	-	21	22.5	23	33.5	33.5	45
C1 ¹	46	46	70	100	130	165	215
C2 ¹	M4 x 0.7P	M4 x 0.7P	M5 x 0.8P	M6 x 1P	M8 x 1.25P	M10 x 1.5P	M12 x 1.75P
C3 ¹	≤11 / ≤12	≤11 / ≤12	≤14 / ≤15.875 / ≤16	≤19 / ≤24	≤32	≤38	≤48
C4 ¹	25	25	34	40	50	60	85
C5 ¹	30	30	50	80	110	130	180
C6 ¹	3.5	3.5	8	4	5	6	6
C7 ¹	42	42	60	90	115	142	190
C8 ¹	29.5	29.5	19	17	19.5	22.5	29
C9 ¹	90.5	99.5	126.5	165	205	254.5	323.5
C10 ¹	8.75	8.75	13.5	10.75	13	15	20.75
B1 _{h9}	5	5	6	10	12	16	20
H1	15	18	24.5	35	43	59	79.5
X DIN5480	-	W16x0.8x 30x18x6m	W22x1.25x 30x16x6m	W32x1.25x 30x24x6m	W40x2x 30x18x6m	W55x2x 30x26x6m	W70x2x 30x34x6m

2. C1~C10是公制标准马达连接板之尺寸, 请上网点选"减速机选用"找出正确之尺寸。

减速机的选用

应用端运动模式

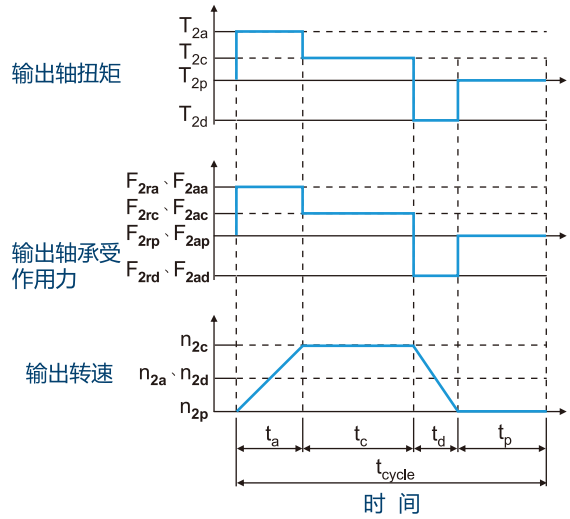

$$1. ED = \frac{t_a + t_c + t_d}{t_{cycle}} \times 100\%, t_{work} = t_a + t_c + t_d$$

下标说明: a. 加速 c. 等速
d. 减速 p. 停止

(Eq.1)

$$2. i \cong \frac{n_m}{n_{work}}$$

n_m 马达输出速度

n_{work} 实际应用速度

(Eq.2)

$$3. T_{2m} = \sqrt[3]{\frac{n_{2a}^3 \times t_a \times T_{2a}^3 + n_{2c}^3 \times t_c \times T_{2c}^3 + n_{2d}^3 \times t_d \times T_{2d}^3}{n_{2a}^3 \times t_a + n_{2c}^3 \times t_c + n_{2d}^3 \times t_d}}$$

(Eq.3)

$$4. T_{2max} = T_{mB} \times i \times k_s \times \eta$$

k_s 负载系数

k_s	周期次数 / 小时
1.0	0 ~ 1,000
1.1	1,000 ~ 1,500
1.3	1,500 ~ 2,000
1.6	2,000 ~ 3,000
1.8	3,000 ~ 5,000

T_{mB} 马达最大输出扭矩

η 减速机运转效率

(Eq.4)

$$5. n_{2a} = n_{2d} = \frac{1}{2} \times n_{2c}$$

$$n_{2m} = \frac{n_{2a} \times t_a + n_{2c} \times t_c + n_{2d} \times t_d}{t_a + t_c + t_d}$$

$$n_{2N} = \frac{n_{1N}}{i}$$

(Eq.5)

$$6. F_{2rm} = \sqrt[3]{\frac{n_{2a}^3 \times t_a \times F_{2ra}^3 + n_{2c}^3 \times t_c \times F_{2rc}^3 + n_{2d}^3 \times t_d \times F_{2rd}^3}{n_{2a}^3 \times t_a + n_{2c}^3 \times t_c + n_{2d}^3 \times t_d}}$$

$$F_{2am} = \sqrt[3]{\frac{n_{2a}^3 \times t_a \times F_{2aa}^3 + n_{2c}^3 \times t_c \times F_{2ac}^3 + n_{2d}^3 \times t_d \times F_{2ad}^3}{n_{2a}^3 \times t_a + n_{2c}^3 \times t_c + n_{2d}^3 \times t_d}}$$

(Eq.6)

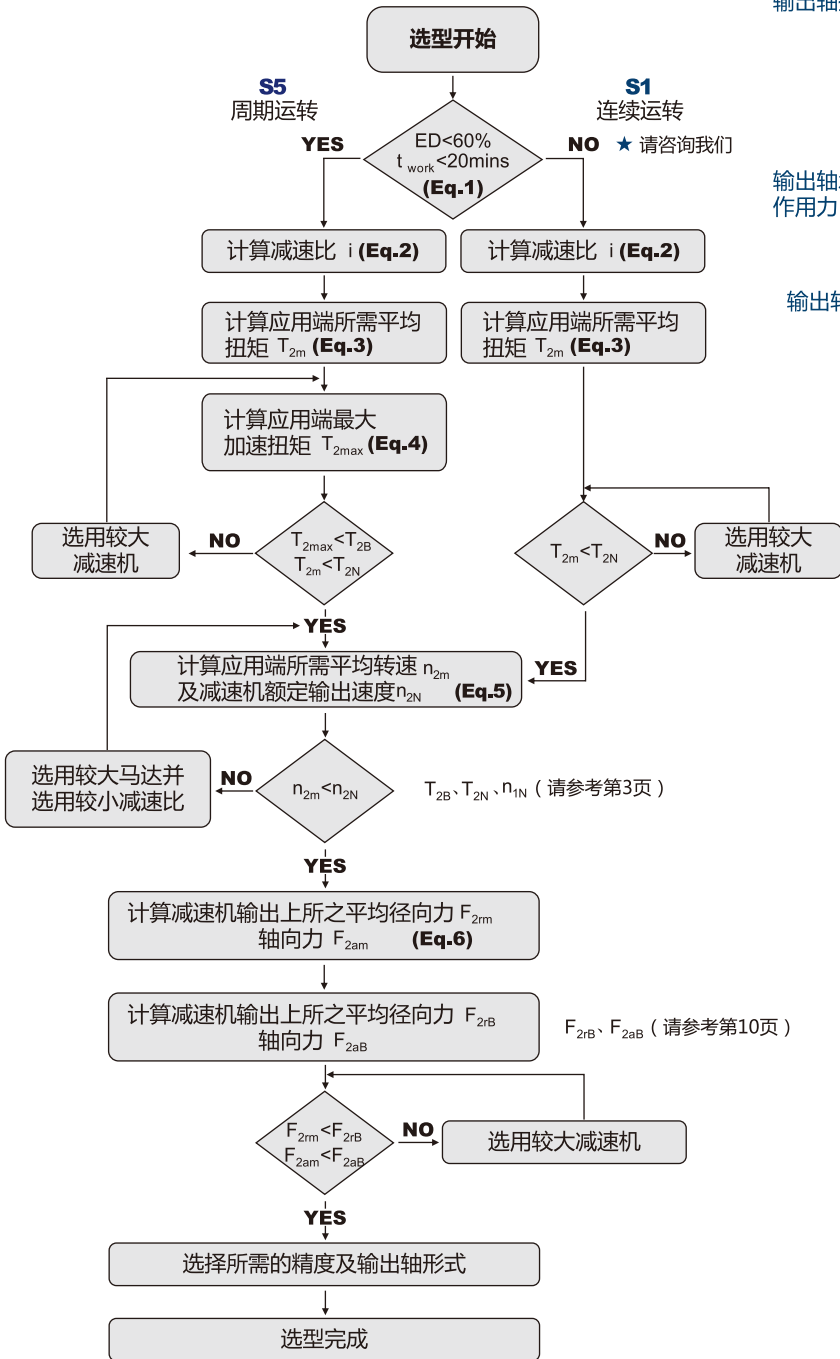

S5周期运转之建议事项

一般的应用惯量须符合以下公式

$$\frac{J_L}{i^2} \leq 4 \times J_m$$

最适当的应用惯量须符合以下公式

$$\frac{J_L}{i^2} \cong J_m$$

J_L 负载惯性

J_m 马达惯性

减速机输出轴的容许径向力及轴向力

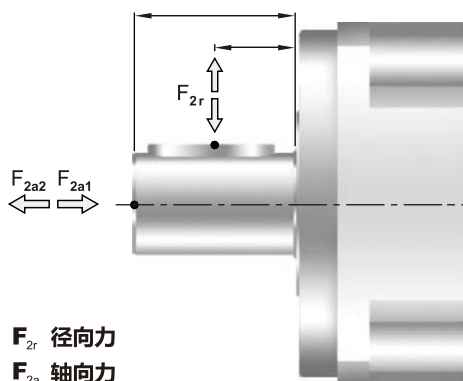

减速机输出轴所能承受的最大径向力及轴向力，端视内部支撑轴承的设计，台湾广用减速机采用大尺寸的轴承及较大跨距的设计，其能承受更大的径向及轴向负荷。

F_{2r} 径向力

F_{2a} 轴向力

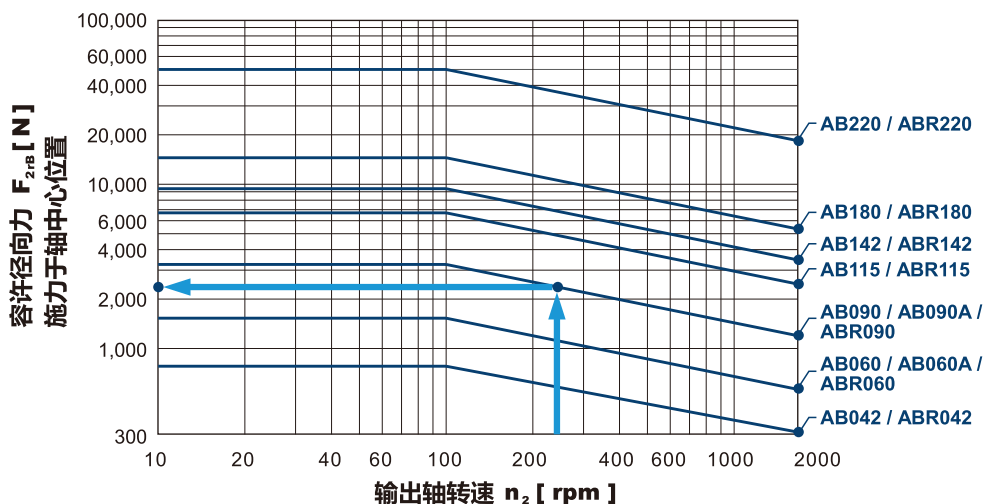

当径向力 F_{2r} 施力于轴中心位置即 $X=1/2xL$ ，不同规格的减速机在不同输出转速运用下，使用寿命为 20,000hr*时，所能承受的容许径向力 F_{2rB} ，请参照左图。

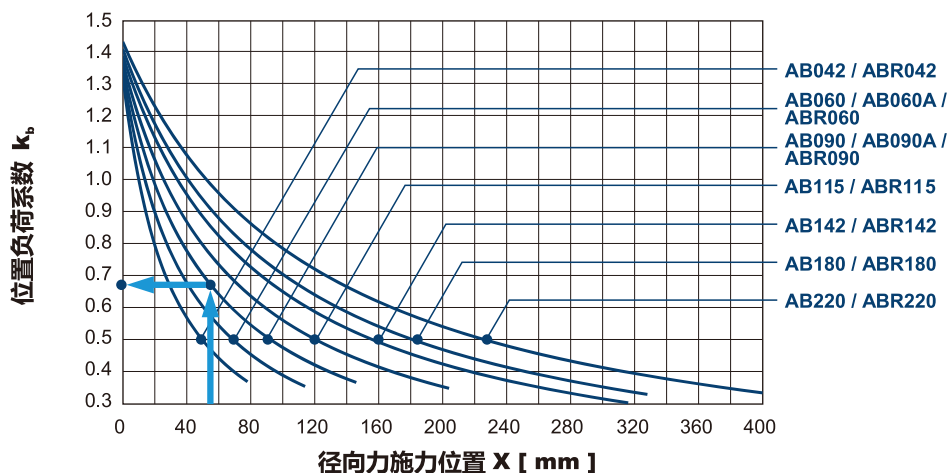

当径向力 F_{2r} 施力不在轴中心位置时，越靠近减速机即 $X < 1/2xL$ ，所能承受的容许径向力变大，越远离减速机即 $X > 1/2xL$ 时，所能承受的容许径向力则变小，藉由左图，依减速机规格及径向力施力位置 X ，查出位置负荷系数 k_b 。

* 连续运转降低使用寿命二分之一

杭州摩森机电科技有限公司
<http://www.hzmosen.com>

咨询热线 0571-86622450